

SPECIFICATION

**ADPV100、200、300、400、500
SERIES AC/DC Adapter**

HGPOWER

HGPOWER ADD: No.1 Guiyang Road ,Lijia ,Wujin, Changzhou, Jiangsu , China
TEL: 86-519-86736307

FAX: 86-519-86731270
E-mail:sales@hgpower.com

RECORD OF ALTERATION

PRODUCT NAME	Switching Power for adapter
MODEL NAME	ADPV100、200、300、400、500

REVISION:

REV	01	02	03	04	05	06	07	08	09	A	B	C	D	E
NO	■													

REV NO	Issue Date	Effective Date	Details of alteration content	Design	Check

TABLE OF CONTENTS

- 1. Scope**
- 2. Connecting form**
 - 2.1 Input connection
 - 2.2 Output cable/connection
 - 2.3 Pin assignments
- 3. Electrical requirements**
 - 3.1 Input
 - 3.1.1 Input Voltage
 - 3.1.2 Input Current
 - 3.1.3 Input Frequency
 - 3.1.4 Inrush Current
 - 3.1.5 Efficiency
 - 3.1.6 Power Factor
 - 3.2 Output
 - 3.2.1 Output Power
 - 3.2.2 Output Voltage
 - 3.2.3 Output Current
 - 3.2.4 Line Regulation
 - 3.2.5 Load Regulation
 - 3.2.6 Cross Regulation
 - 3.2.7 Output Ripple And Noise Voltage(Papd)
 - 3.2.8 Output Transients Response
 - 3.2.9 Output Voltage Drift
 - 3.2.10 Output Overshoot
 - 3.2.11 Output Protection

- 3.2.11-1 Over voltage protection
- 3.2.11-2 Output short circuit/Overload protection
- 3.2.12 output rise time
- 3.2.13 Turn-On Delay
- 3.2.14 Output Hold-Up- Time
- 3.2.15 Power good/bad Signal
- 3.2.16 Temperature Coefficient

4. Environmental requirements

- 4.1 Temperature
- 4.2 Altitude
- 4.3 Humidity
- 4.4.1 Vibration
- 4.4.2 Shock/Fall
- 4.5 Input Transient Susceptibility
- 4.6 AC-Line Input Inrush Noise

5. Safety requirements

- 5.1 Dielectric Withstand Voltage
- 5.2 Leakage Current
- 5.3 Insulation Resistance
- 5.4 Safety Spacing
- 5.5 Safety Standards Approval
 - 5.5.1 UL 、 C-UL Standards
 - 5.5.2 Marking
- 5.6 Reliability

6. EMI Requirements

- 6.1 Conduction
- 6.2 Radiation

7. RoHS compliant

8. Size

1. Scope

This is the engineering specification of 3~ 6Watt power wall plug-in AC/DC adapter , with wide voltage 100~240V AC input, single DC output, packed into a molded plastic case . Models covered :

ADPV100-HGP06A06 (6V/1A ---6W)

ADPV200- HGP05A45 (4.5V/1.2A ---5.4W)

ADPV300- HGP05A05 (5V/1.0A ---5W)

ADPV400- HGP05A09 (9V/0.6A ---5.4W)

ADPV500- HGP05A12 (12V/0.45A ---5.4W)

2. Connector

The following specifies the input and output connection requirement of the power supply.

2.1 Input connector

Two sheet copper socket connector or two wire

2.2 Output cable/connector

A two wire cable with standard DC connector .

2.3 Pin assignments

INPUT: Pin1~Line(L)
Pin2~Neutral(N)

OUTPUT: Outside ~+V
Inside~-V

3. Electrical requirements

Unless specified otherwise, all specifications are at nominal input voltage, full load, 25°C, PSU at warmed up condition.

3.1 Input

The operating conditions with respect to the AC input voltage are described in this section.

3.1.1 Input Voltage

The operating voltage range is 100V to 240VAC.

3.1.2 Input Current

When the input voltage is 100VA at 6W, then the max input current shall be less then0.3A

When the input voltage is 240VA at 6W, then the max input current shall be less then0.2A

3.1.3 Input Frequency

Input frequency range shall be 50/60Hz.

3.1.4 Inrush Current

Maximum inrush shall be less then 15A at 240VAC.

3.1.5 Efficiency

The efficiency of the power supply is 66% nominal, Measured at Full Load and nominal AC Input voltage of 220VAC ,25°C with the PSU warmed up, at output. O/P Cable drop of 0.3V typical is removed for this calculation.

3.1.6 Power Factor

Input AC voltage connects to internal diode bridge rectifier and Filter6W, output load is ≥ 0.60

3.2 Output

The operating conditions for the regulated DC output are described in this section.

3.2.1 Output Power

Depends on models, possible Max. Output power is 6W with O/P voltage of 6V and above, Max rated power for a specific model ADPV(100、200、300、400、500)-HGPxxAyy , “xx” is Watt .

3.2.2 Output Voltage

Initial point voltage is measured at Min. Load/Half Load/Max. Load, at nominal input AC voltage, The nominal output voltage of a specific model (ADPV100、200、300、400、500)-HGPxxAyy , “yy” is volt. This voltage change is indicative of change due to process variation and change due to load variation.

The set point tolerance is measured with reference to the respective nominal Voltage and expressed as percentage of nominal output voltage.

Model	Output	Nominal voltage	Set point tolerance	User adjust
ADPV100-HGP06A06	+V	+6V	<4%	NA
ADPV200-HGP05A45	+V	+4.5V	<4%	NA
ADPV300-HGP05A05	+V	+5V	<4%	NA
ADPV400-HGP05A09	+V	+9V	<4%	NA
ADPV500-HGP05A12	+V	+12V	<4%	NA

3.2.3 Output Current

Model	Output	Min.Load current	Max.Load current	Limit Current
ADPV100-HGP06A06	+V=6V	0A	1A	1.2A
ADPV200-HGP05A45	+V=4.5V	0A	1.2A	1.5A
ADPV300-HGP05A05	+V=5V	0A	1.0A	1.2A
ADPV400-HGP05A09	+V=9V	0A	0.6A	0.8A
ADPV500-HGP05A12	+V=12V	0A	0.45A	0.7A

3.2.4 Line Regulation

Regulation is measured by varying the line voltage from 100~240VAC,at full load.

Model	Output	Tolerance
All	+ V	<4%

3.2.5 Load Regulation

Measured by varying the load current from MIN Load to FULL load at nominal AC input voltage. Measured at O/P power cord end. This measures output voltage variation of a unit due to load change and is indicative of design capability. The tolerance is measured with reference to the respective nominal voltage and expressed as percentage of nominal output voltage.

Model	Output	Tolerance
All	+ V	<5%

3.2.6 Cross Regulation

Measured at 50% load on output while any other output load changed by 50%.

ALL Models

3.2.7 Output Ripple And Noise Voltage (PAPD)

Measured At Full Load, 20MHz Bandwidth, With A 0.1uf Ceramic Cap and a 47uF Tent. Cap/E-Cap. Connected at the measurement point. The maximum PARD PK-PK ripple and noise is indicated below.

Model	Output	Max pk-pk
ADPV100-HGP05A06	+V=6V	<100 mV
ADPV200-HGP05A45	+V= 4.5V	<100 mV
ADPV300-HGP05A05	+V=5V	<100 mV
ADPV400-HGP05A09	+V=9V	<120 mV
ADPV500-HGP05A12	+V=12V	<150 mV

3.2.8 Output Transient Response

The load current of measured output is changed between 10% to 100% max load for all models, at 0.1A/sec slew rate, at 100/120Hz, 50% duty cycle. The recovery time and excursion is measured when the output voltage has recovered to within 1% of the load regulation band. Expressed as percentage of the nominal voltage,

The recovery time to regulation<1ms and Max. Excursion from regulation<3% when the all models nominal output voltage.

3.2.9 Output Transient Response

Long-term output voltage drift over 1000 hours of operation, at +V is typically less then 0.5%.

3.2.10 Output Overshoot

The overshoot voltage as a percentage of nominal output voltage at initial power up of the PSU, at 5.4W full load condition is indicated below. Measured with ref, to the O/P regulation band.

The output overshoot <5% when the all models nominal output voltage.

3.2.11 Output Protection

The power supply load shall be protected against a fault condition described below.

3.2.11-1 Over Voltage

N/A

3.2.11-2 Output Short Circuit / Overload Protection

The PSU shall be protected against overload as per section 3.2.3. The power supply will be protected against output short circuit. Short circuit current shall be less than 0A. Under all conditions. Output voltage of less than 50% +V constitutes a short. The PSU will self recover within a max. of 30 sec. After removal of the fault.

3.2.12 Output Rise Time

The time taken by the output to rise from 10% to 90% of the final steady state value, should be as below.

The Max rise time < 10ms, when the all models nominal output voltage.

3.2.13 Turn-On Delay

The run-on delay time, from the time AC power is applied to the PSU till the O/P voltage is within the regulation band. Shall be less than 2 seconds at 100VAC. Cold start.

3.2.14 Output Hold-Up- Time

The power supply shall maintain the output within its voltage/current specification for more than 10ms. After any loss of AC input voltage. Measured at nominal input voltage of 100-240VAC and at point when output is crossing regulation band.

3.2.15 Remote Sense

N/A

3.2.16 Power Fall / Power Good Signal

N/A

3.2.17 Temperature Coefficient

Temperature coefficient over the entire operating temperature range of 0°C to 40°C after one hour warm-up will be as follows.

The temperature coefficient < 2.4mV/°C when the all models nominal output voltage.

4. Environmental Requirements

4.1 Temperature

Operating temperature range is -10°C to 40°C at the respective rated output power, with free air convection. Surface temperature shall be less than 60°C at 25°C operating temperature. Non-operating range: -40°C to 85°C.

4.2 Altitude

Maximum operating altitude: 10,000 feet. Maximum Non-operating altitude: 40,000 feet.

4.3 Humidity

Non-condensing relative humidity range: 5% to 95%.

4.4.1 Vibration

The power supply shall meet operating, non-operating and package vibration,

Vibration	frequency	acceleration	tow time	cycle
Operating	5-500Hz	0.5G	15min,xyz all 15min	2
Non-operating	5-500Hz	1G	15min,xyz all 15min	2
Package	5-500Hz	1.5G	15min,xyz all 30min	2

4.4.2 Shock

The power supply shall meet operating and non operating shock. On floorboards thick for 10mm wood block.

Shock	height	direction	cycles
Operating	0.3m	xyz all 3 times	6
Non-operating	1.0m	xyz all 3 times	6

4.5 Input Transient Susceptibility

The unit shall comply with requirements of IEC 1000-4-2, IEC 1000-4-4 and IEC 1000-4-5, will withstand ESD of 8K. Contact Discharge, will withstand ESD of 12K Air Discharge, 10 strides, both +ve and -ve, as per IEC 1000-4-2.

4.6 AC-Line Input Inrush Noise

Minimum dielectric AC-line inrush voltage noise: Between AC input L to N:

Inrush noise	Tr /Td	Voltage	Phase	time	cycles
Operating	1.2us/50us	2.0KV	0°	1min	10
			90°		10
			270°		10
			360°		10

5. Safety Requirements

5.1 Dielectric Withstand Voltage

Minimum dielectric voltage: Between input to output: 3000VAC/1 minute. Leakage current shall be 5mA maximum.

5.2 Leakage Current

Maximum leakage current form primary to secondary shall be 0.25mA. Minimum voltage 240VAC

5.3 Insulation Resistance

Minimum insulation resistor from primary to secondary shall be 100M Ω . Voltage DC 500V.

5.4 Safety Spacing

6.4mm minimum between primary and secondary

5.5 Safety Standards Approval

The power supply will meet Class II, SELV of the following safety agency requirements

5.5 UL Standards

- 5.5.1
- | | |
|---------------------------|--|
| 1. UL1492-2 edition | The standard for audio-video products and accessories. |
| 2. UL6500 edition
C-UL | The standard for products and accessories. |
| 1. CSA C22.2 No.1 | Safety of radio, television and electrical equipment. |
| 2. CSA C13.2 No.1 | Safety of radio, television and electrical equipment. |
| 3. CSA C22.2 No.950 | Safety of information technology equipment, including electrical business equipment. |
| 4. CSA-E65 | The standard for information technology equipment, including electrical business equipment and associated equipment. |

- 5.5.2 Marking
With the following marking: UL,C-UL, CE

- 5.6 Reliability
MTBF@ 25°C shall be 300,000 hours min.

6. EMI Requirements

EMI Standard: EN55022 CLASS B, EN6100-3-2.3, FCC CLASS B

- 6.1 Conduction
The adapter will conform to FCC PART15 Class B, VICC Class B, and CISPR Pub.13 Class B.

- 6.2 Radiation
The adapter will conform to FCC PART15 Class B, VICC Class B, and CISPR Pub.13 Class B.

7. RoHS compliant

7. Size : 67x43x23mm , as following drawing :

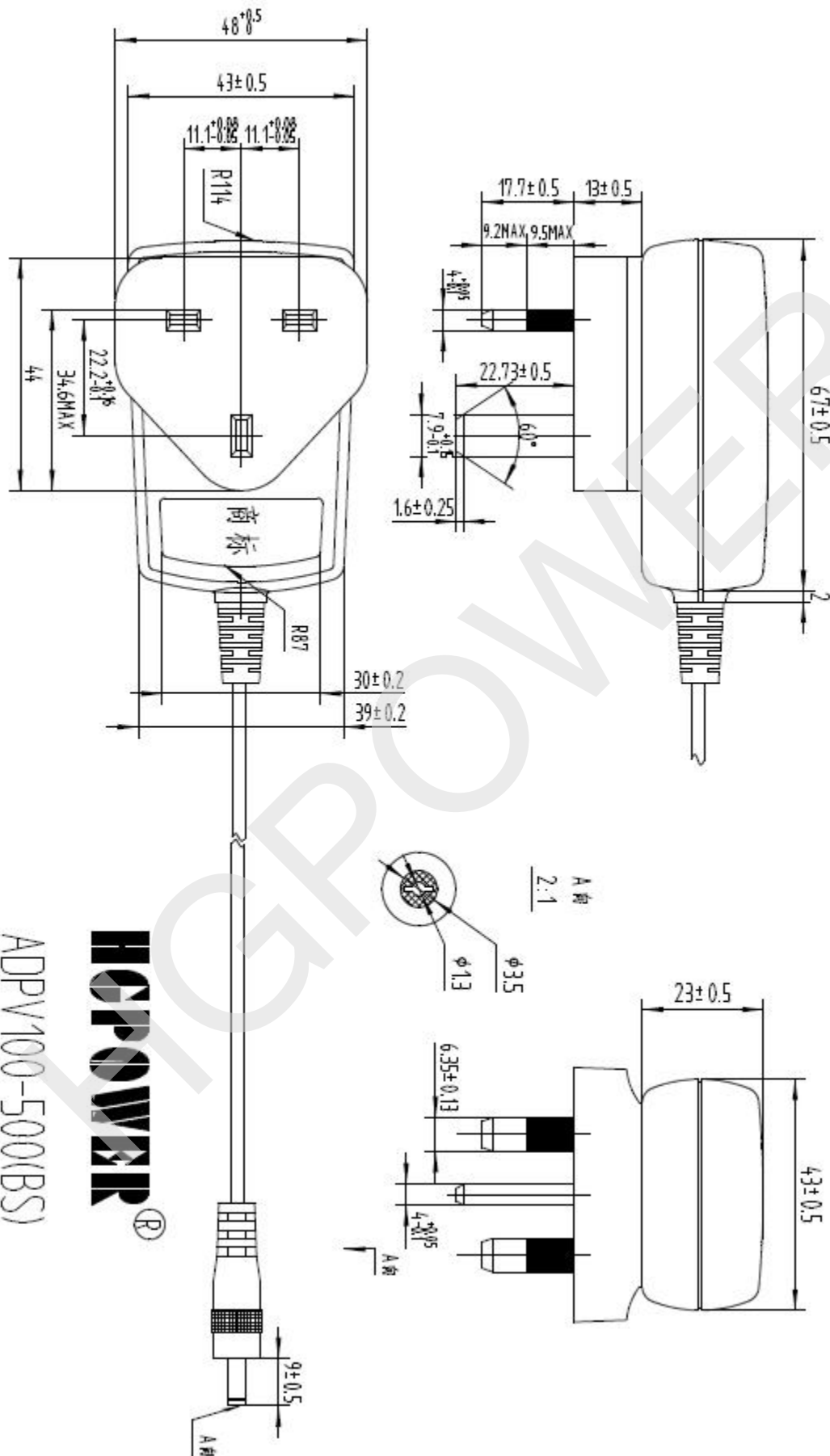

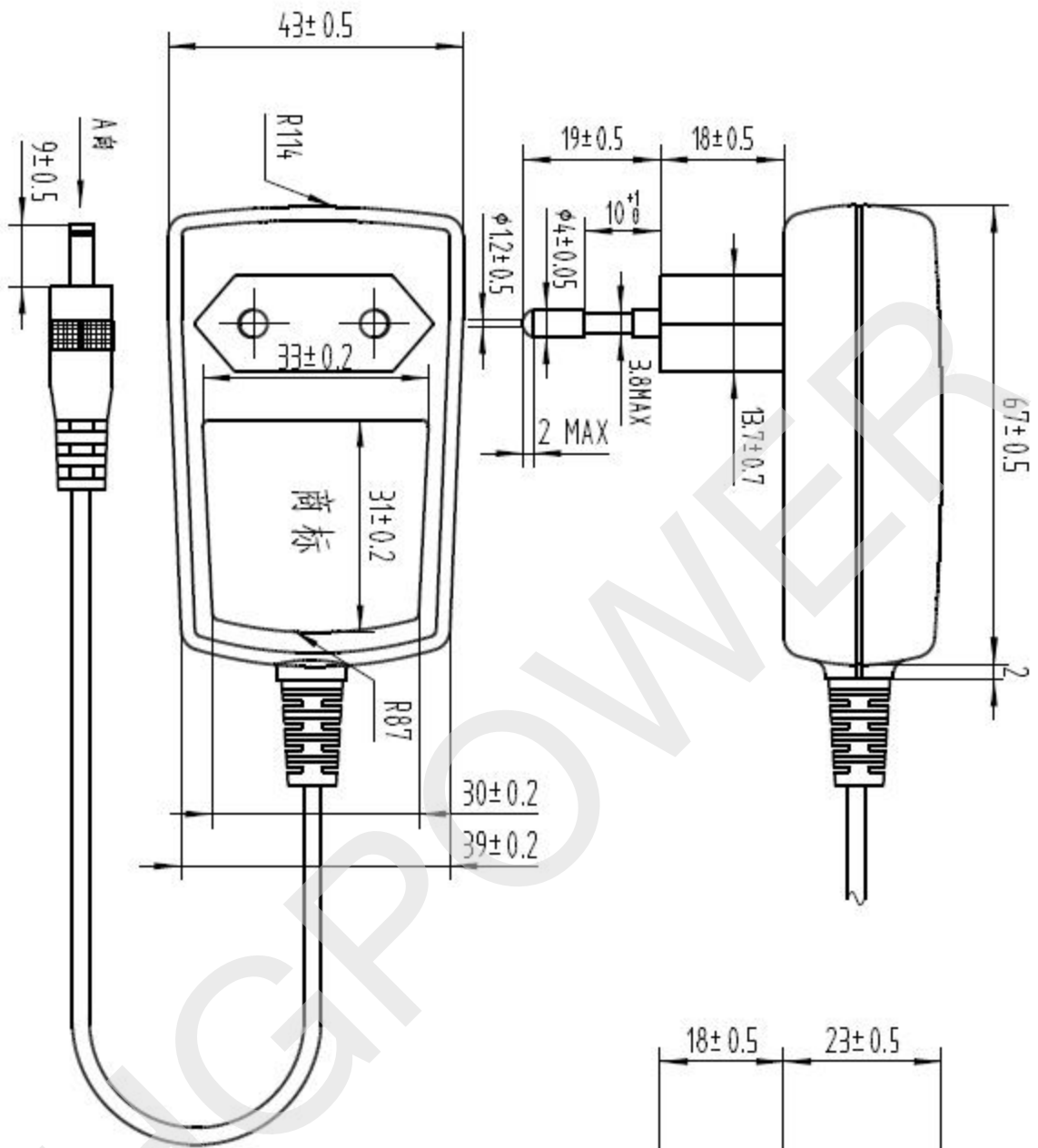

HGPOWER®
ADPV100-500(CE)

