

HGPOWER®

SPECIFICATION

ADPV88 series AC/DC Adapter

HGPOWER ADD: No. Guiyang Road ,Lijia ,Wujin, Changzhou, Jiangsu , China
TEL: 86-519-86736307

FAX: 86-519-86731270
E-mail: sales@hgpower.com

1. SCOPE

The power supply specification is as following: 70W~90Watt power AC/DC desk top adapter, with wide voltage 100V--240V AC input, single DC output, packaged into a fully enclosed plastic case with IEC320-C13 or IEC60320-C8 input connector and the DC cable with 2PIN or 3PIN plug.

Models covered: ADPV88A-HGP-AD84A12
 ADPV88B-HGP-AD80A15
 ADPV88C-HGP-AD90A16
 ADPV88D-HGP-DA90A18
 ADPV88E-HGP-AD90A19
 ADPV88F-HGP-AD90A20
 ADPV88G-HGP-AD88A22
 ADPV88H-HGP-AD90A24
 ADPV88I-HGP-AD90A30
 ADPV88J-HGP-AD96A48

2. CONNECTIONS

The following specifies the input and output connection requirement of the power supply.

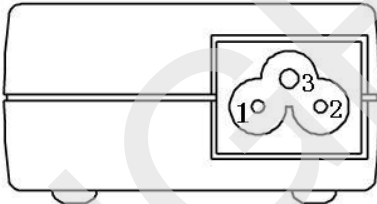
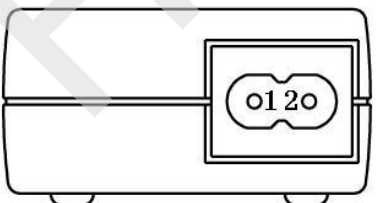
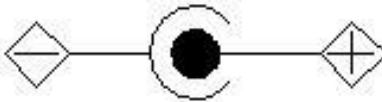
2.1	INPUT CONNECTOR Three wire, 3P,IEC-C13 connector or IEC60320-C8 input connector	
2.2	OUTPUT CABLE/CONNECTOR A two wire cable with standard DC connector, or 3 wire with 3PIN DC connector .	
2.3	PIN ASSIGNMENTS	
	INPUT(J1)	OUTPUT(CSI)
3P	Pin 1:Line Pin 2:Neutral Pin 3:GND 	
2P	Pin 1:Line Pin 2:Neutral 	Outside: GND (-) Inside: +Vout 

3. ELECTRICAL REQUIREMENTS

(Unless specified otherwise, all specifications are at nominal input voltage, full load, 25deg C, The PSU should be under warmed condition.)

3.1	INPUT The operating conditions with respect to the AC input voltage are described in this section.
3.1.1	INPUT VOLTAGE The operating voltage range is: 100V to 240 VAC.
3.1.2	INPUT CURRENT

	0.6~2.7A
3.1.3	INPUT FREQUENCY Input frequency range shall be 47-63Hz.
3.1.4	INRUSH CURRENT Maximum inrush shall be less than 40A at 240VAC.
3.1.5	EFFICIENCY The efficiency of the power supply is 85% nominal, Input voltage of 220VAC. 25°C with the PSU warmed up, O/P Cable drop of 0.30V typical is removed for this calculation. Measured at Full Load and nominal AC, the efficiency should be not less than 88%, at full load and 100VAC, it should be not less than 86%.
3.1.6	POWER FACTOR Input AC voltage connects to internal diode bridge rectifier and Filter, 90W output, AC100V~AC240V, the load power factor is ≥ 0.60 .
3.2	OUTPUT POWER The operating conditions for the regulated DC output are described in this section.
3.2.1	OUTPUT POWER Depends on models, possible Max. Output power is 96W, the Max rated power for a specific model ADPV88-HGPxxFSyyE is "XX" Watt.

3.2.2	OUTPUT VOLTAGE Initial point voltage is measured at Min. Load/ Half Load/Max. Load, at nominal input AC voltage, The nominal output voltage of a specific model ADPV88-HGPxxFSyyE is "YY" volt. This voltage change is indicative of change due to process variation and change due to load variation. The set point tolerance is measured with reference to the respective nominal Voltage and expressed as percentage of the nominal output voltage.				
	Model	OUTPUT	NOMINAL VOLTAGE	SETPOINT TOLERANCE	User Adjust
	ADPV88A-HGP-AD84A12	+Vout(I)	+12VDC	< 4 %	NA
	ADPV88B-HGP-AD80A15	+Vout(I)	+15VDC	< 4 %	NA
	ADPV88C-HGP-AD90A16	+Vout(I)	+16VDC	< 4 %	NA
	ADPV88D-HGP-AD90A18	+Vout(I)	+18VDC	< 4 %	NA
	ADPV88E-HGP-AD90A19	+Vout(I)	+19VDC	< 4 %	NA
	ADPV88F-HGP-AD90A20	+Vout(I)	+20VDC	< 4 %	NA
	ADPV88G-HGP-AD88A22	+Vout(I)	+22VDC	< 4 %	NA
	ADPV88H-HGP-AD90A24	+Vout(I)	+24VDC	< 4 %	NA
	ADPV88I-HGP-AD90A30	+Vout(I)	+30VDC	< 4 %	NA
	ADPV88J-HGP-AD96A48	+Vout(I)	+48VDC	< 4 %	NA

3.2.3 OUTPUT CURRENT
 The maximum load capacitance shall be less than 6800uF for any nominal output voltage below 24V and 10000uF for any nominal o/p volt above 12V. Any load capacitance shall be discharged below 1V before the PSU is turned on. The max. continuous rated output current for the specific models is listed below. Under non-overload, max permissible P-P power is 90W, protection (Over Current Protection) shall not be activated greater than the Min. P-P current.

Model	Output	MIN. Load Current	MAX. Load Current	Peak Current limit min(P-P)
ADPV88A-HGP-AD84A12	+Vout(I)=12V	0A	7.0A	8.0A
ADPV88B-HGP-AD80A15	+Vout(I)=15V	0A	6.0A	7.0A
ADPV88C-HGP-AD90A16	+Vout(I)=16V	0A	5.6A	6.6A
ADPV88D-HGP-AD90A18	+Vout(I)=18V	0A	5.0A	6.0A
ADPV88E-HGP-AD90A19	+Vout(I)=19V	0A	4.7A	5.7A
ADPV88F-HGP-AD90A20	+Vout(I)=20V	0A	4.5A	5.5A
ADPV88G-HGP-AD88A22	+Vout(I)=22V	0A	4.0A	5.0A
ADPV88H-HGP-AD90A24	+Vout(I)=24V	0A	3.75A	4.75A
ADPV88I-HGP-AD90A30	+Vout(I)=30V	0A	3.0A	4.0A
ADPV88J-HGP-AD96A48	+Vout(I)=48V	0A	2.0A	3.0A

3.2.4 LINE REGULATION
 Regulation is measured by varying the line voltage from 100-240VAC, at full load.

Model	OUTPUT	TOLERANEE
ALL	+Vout(I)	<4%

3.2.5 LOAD REGULATION
 Measured by varying the load current from MIN Load to FULL load at nominal AC input voltage. Measured at o/p power cord end. This measures output voltage variation of a unit due to load change and is indicative of design capability. The tolerance is measured with reference to the respective nominal Voltage and expressed as percentage of nominal output voltage.

Model	OUTPUT	TOLERANCE
ALL	+Vout(I)	<3%

3.2.6 CROSS REGULATION
 Measured at 50% load on output while any other output load changed by 50%.

3.2.7 OUTPUT RIPPLE AND NOISE VOLTAGE (PAPD)
 Measured at full load, 20MHz bandwidth, with a 0.1uF Ceramic Cap and a 47uF Tant. Cap/E-Cap. connected at the measurement point. The maximum PARD PK-PK ripple and noise is indicated below.

Model	Output	Max pk-pk
ADPV88A-HGP-AD84A12	+Vout(I)=12V	<150mV
ADPV88B-HGP-AD80A15	+Vout(I)=15V	<250mV
ADPV88C-HGP-AD90A16	+Vout(I)=16V	<300mV
ADPV88D-HGP-AD90A18	+Vout(I)=18V	<300mV
ADPV88E-HGP-AD90A19	+Vout(I)=19V	<300mV
ADPV88F-HGP-AD90A20	+Vout(I)=20V	<300mV
ADPV88G-HGP-AD88A22	+Vout(I)=22V	<300mV
ADPV88H-HGP-AD90A24	+Vout(I)=24V	<300mV
ADPV88I-HGP-AD90A30	+Vout(I)=30V	<300mV
ADPV88J-HGP-AD96A48	+Vout(I)=48V	<300mV

3.2.8	<p>OUTPUT TRANSIENT RESPONSE The load current of measured output is changed between 10% to 100% max load for all models, at 0.1A/sec slew rate, at 100/120Hz, 50% duty cycle. The recovery time and excursion is measured when the output voltage has recovered to within 1% of the load regulation band. Expressed as percentage of the nominal voltage.</p>
-------	---

Model	Output	RECOVERY TIME To regulation	MAX. EXCURSION From Regulation
ALL	+Vout(I)	<1ms	<3%

3.2.9	<p>OUTPUT TRANSIENT RESPONSE Long-term output voltage drift over 1000 hours of operation, at Vout (I) is typically less than 0.5%.</p>
3.2.10	<p>OUTPUT OVERSHOOT The overshoot voltage as a percentage of nominal output voltage at initial power up of the PSU, at 90w full load condition is indicated below. Measured with ref. to the o/p regulation band.</p>

Model	OUTPUT	OVERSHOOT
ALL	+Vout(I)	<5%

3.2.11	<p>OUTPUT PROTECTION The power supply load shall be protected against a fault condition described below.</p>
3.2.11.1	<p>OVERVOLTAGE Redundant Feedback type. The load is protected against any output over voltage under any fault condition.</p>
3.2.11.2	<p>OUTPUT SHORT CIRCUIT /OVERLOAD PROTECTION The PSU shall be protected against overload as per section 3.2.3. The power supply will be protected against output short circuit. Short circuit current shall be close to 0A rms. Under all conditions. Output voltage of less than 40%Vout(I) constitutes a short. The PSU will self recover within 3sec. after removal of the fault.</p>
3.2.12	<p>OUTPUT RISE TIME The time taken by the output to rise from 10% to 90% of the final steady state value should be as below.</p>

Model	OUTPUT	MAX RISE TIME
ALL	+Vout(I)	<10ms

3.2.13	<p>TURN-ON DELAY The rum-on delay time, from the time AC power is applied to the PSU till the o/p voltage is within the regulation band. Shall be less than 2 seconds at 100 VAC. cold starts.</p>
--------	--

3.2.14	OUTPUT HOLD-UP-TIME The power supply shall maintain the output within its voltage/current specifications for more than 10sec. after any loss of AC input voltage. Measured at nominal input voltage of 100-240VAC, more than 50% load and at point when output is crossing regulation band.
3.2.15	REMOTE SENSE N/A

3.2.16	POWER FALL/POWER GOOD SIGNAL LED
3.2.17	TEMPERATURE COEFFICIENT Temperature coefficient over the entire operating temperature range of 0°C to 40°C after one hour warm-up will be as follows:

Model	OUTPUT	TEMP. COEFF.
ALL	+Vout(I)	<2.4mV/°C

4. ENVIRONMENTAL REQUIREMENTS

4.1	TEMPERATURE Operating temperature range is -10°C to 40°C at the respective rated output power, with free air convection. Non-operating temperature range: -40°C to 85°C.				
4.2	ALTITUDE Maximum operating altitude: 10,000 feet, Maximum Non-operating altitude: 40,000 feet.				
4.3	HUMIDITY Non-condensing relative humidity range: 5% to 95%.				
4.4.	VIBRATION The power supply shall meet operating, non operating and package vibration,				
	vibration	frequency	acceleration	tow time	cycles
	Operating	5-9Hz	2G	15min,XYZ all 15 min	2
Non operating	9-500Hz	1G	15min,XYZ all 15 min	2	
4.5	INPUT TRANSIENT SUSCEPTIBILITY The unit shall comply with requirements of IEC61000-4-2, IEC 1000-4-4 and IEC 1000-4-5, both +ve and -ve, Air Discharge will withstand ESD of 15KV, Contact Discharge will withstand ESD of 20K, 1.2 μ S/50 μ S, (0,90° ,180° ,270°) 10 times/min				

4.6	THERMAL SHUTDOWN The power supply includes the over-temperature protection, surpasses the hypothesis temperature, it will knock off, and eliminate the fault, self-recovery.
-----	--

5. SAFETY REQUIREMENTS

5.1	DIELECTRIC WITHSTAND VOLTAGE Minimum dielectric withstands voltage: Between input to output: 3000VAC rms/1 minute. Leakage current shall be 10mA maximum.
5.2	LEAKAGE CURRENT Maximum leakage current from primary to secondary shall be 0.35mA , Minimum voltage 250VAC rms.
5.3	SAFETY SPACINGS 6.4mm minimum between primary and secondary.

5.4	SAFETY STANDARDS APPROVAL The power supply will meet Class II, SELV of the following safety agency requirements:	
	UL STANDARDS	
	1.	UL1492-2 edition The standard for audio-video products and accessories.
	2.	UL6500 edition The standard for products and accessories.
	C-UL	
	1	CSA C22.2 No.1 Safety of radio, television and electrical equipment.
	2	CSA C13.2 No.1 Safety of radio, television and electrical equipment.
	3	CSA C22.2 No.950 Safety of information technology equipment, including electrical business equipment.
	4	CSA-E65 The standard for information technology equipment, including electrical business equipment and associated equipment.
5.5	LIFE	
	5.1.1	MTBF@ 25°C shall be 300,000 hours min.

6. EMI REQUIREMENTS,

EMI STANDARD: EN55022 CLASS B, EN61000-3-2,2. FCC Class B. GB9254-1998 , GB13837-2003, EMI, FCC CLASS A.

7. RoHS compliant

8. Size : 132x60x35.5mm , see following drawing .

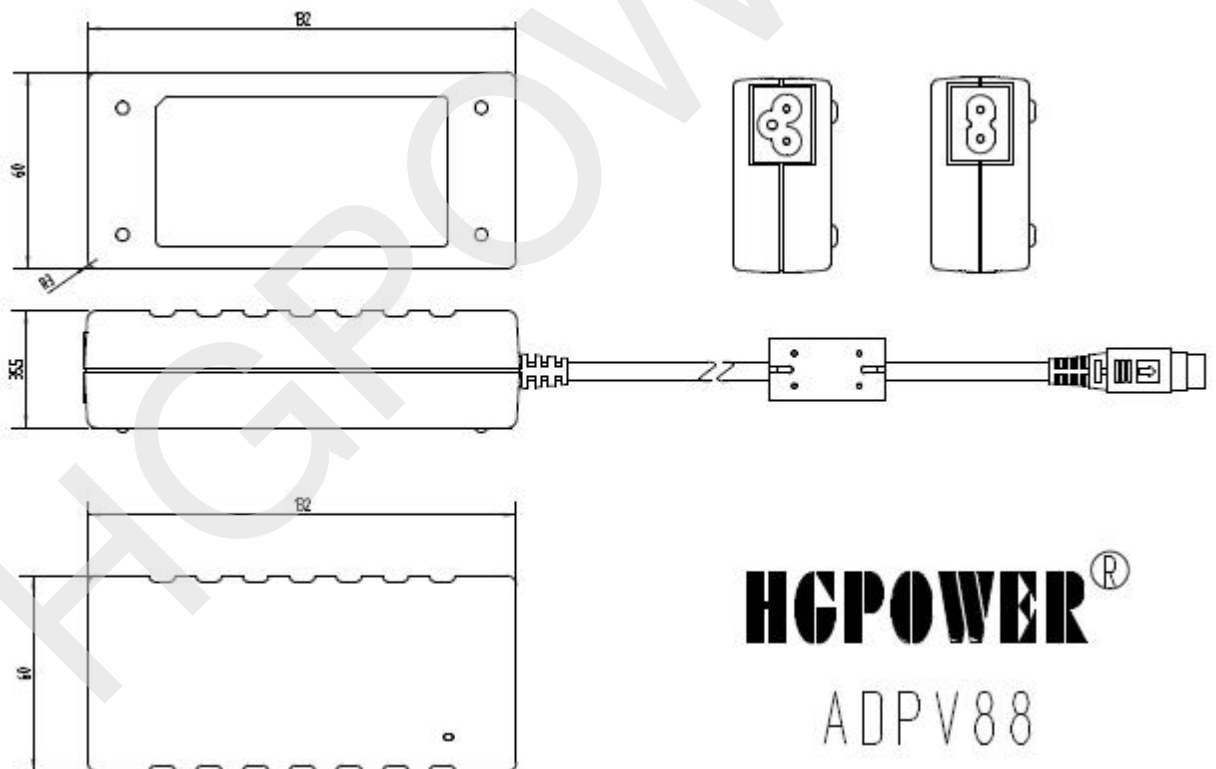

HCPOWER[®]
ADPV88