



Features:

- Constant voltage mode power supply
- 200-240V AC input only
- Fully encapsulated with IP67 level
- Protections: Short circuit/Over Voltage
- Small and compact size
- Class 2 power unit
- 100% full load burn-in test
- Suitable for LED lighting and moving sign applications
- 2 years warranty

SPECIFICATION:

MODEL		LV100-12E	LV100-24E
OUTPUT	DC VOLTAGE	12V	24V
	RATED CURRENT	8.3A	4.2A
	CURRENT RANGE	0~8.3A	0~4.2A
	RATED POWER	99.6W	100.8W
	RIPPLE & NOISE (max.)	120mVp-p	200mVp-p
	VOLTAGE TOLERANCE	±3.0%	
	LINE REGULATION	±1.0%	
	LOAD REGULATION	±2.0%	
	SETUP,RISE TIME	500ms,250ms/240VAC 500ms at full load	
HOLD UP TIME (Typ.)	50ms/240VAC at full load		
INPUT	VOLTAGE RANGE	200-240VAC	
	FREQUENCY RANGE	47~63Hz	
	EFFICIENCY (Typ.)	82% full load	84% full load
	AC CURRENT	0.70A/240AC	
	INRUSH CURRENT (max.)	COLD STAT 70A/230VAC	
	LEAKAGE CURRENT	0.25mA/240VAC	
PROTECTION	SHORT CIRCUIT	Protection type: Hiccup mode, recovers automatically after fault condition is removed.	
	OVER VOLTAGE	Above 13-20V	Above 25-36V
ENVIRONMENT	WORKING TEMP.	-10~50°C	
	WORKING HUMIDITY	20~90% RH non-condensing	
	STORAGE TEMP., HUMIDITY	-40~80°C, 10~95% RH	
	TEMP. COEFFICIENT	±0.03%/°C (0~50°C)	
	VIBRATION	10 ~ 500Hz, 2G 10min./1cycle, period for 60min. each along X,Y, Z axes	
SAFETY & EMC	SAFETY STANDARDS	Design refer to UL1310 Class 2,TUV EN62368-1, EN61347-2-13, CAN/CSA C22.2 No. 223-M91, meet IP67	
	WITHSTAND VOLTAGE	I/P-O/P:3KVAC	
	ISOLATION RESISTANCE	I/P-O/P:>100M Ohms / 500VDC / 25~70% RH	
	EMI CONDUCTION & RADIATION	Compliance to EN55032:2015+A11:2020	
DIMENSION		162*42.5*30mm (L*W*H)	

Mechanical Specification

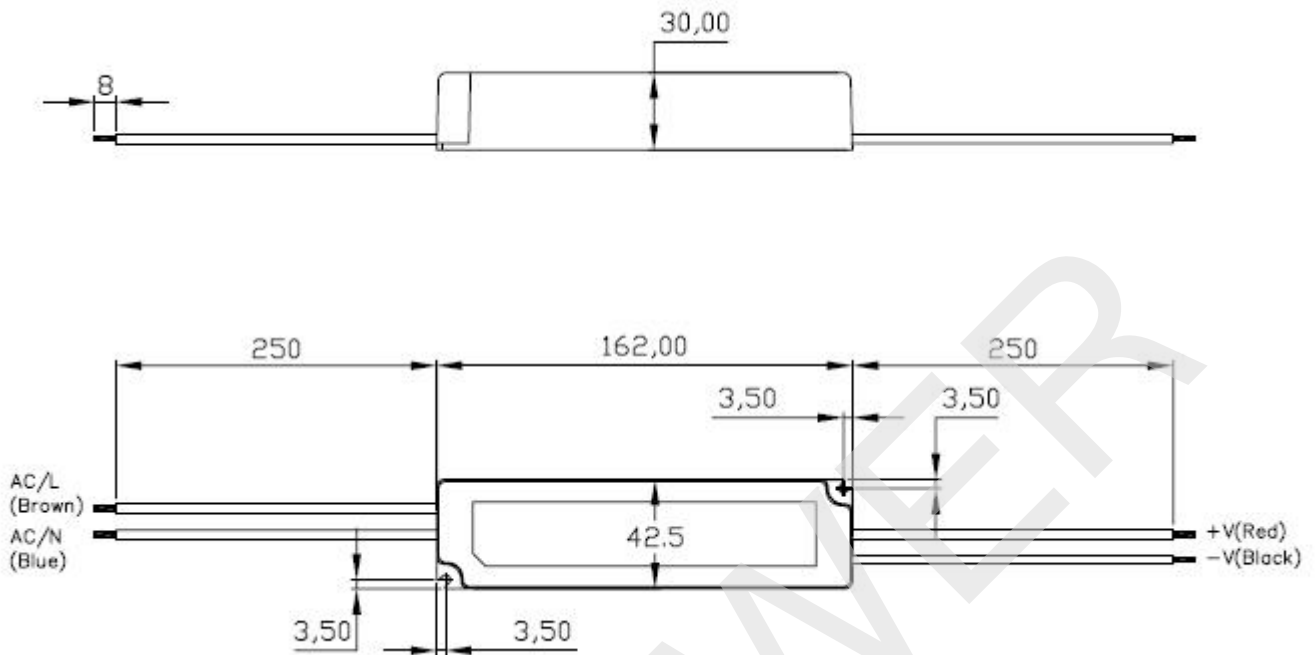

Block Diagram

